

BIG BUBBA® COMMERCIAL CARTRIDGE FILTER SYSTEM

MODEL NO.	ORDERING CODES	INLET (A)	OUTLET (B)	OVERALL HEIGHT (C)	OVERALL DEPTH (D)	OVERALL WIDTH (E)
BBH-150	68100639	21.6"	4.0"	42.6"	13.5"	16.75"
BBH-150-NP	68100640	21.6"	4.0"	39.45"	13.5"	16.75"

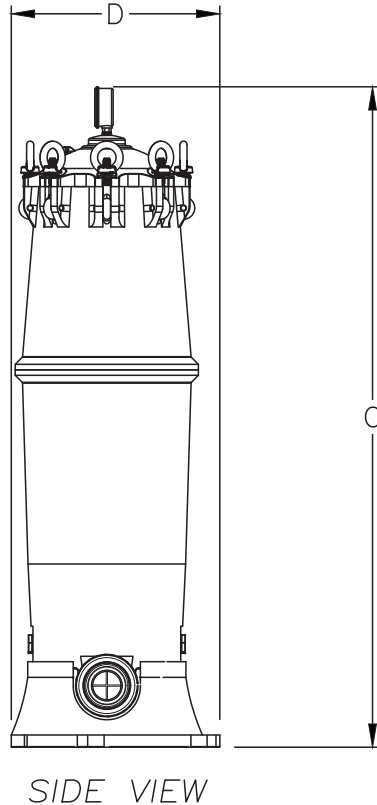
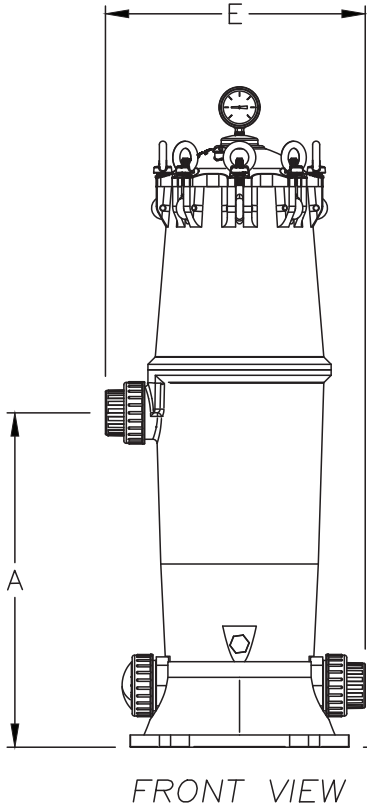

NOTE:
DIMENSIONS ARE SUBJECT TO CHANGE WITHOUT NOTICE

CONFIDENTIAL & PROPRIETARY

This Document including all information contained thereon is the exclusive and confidential property of Watts Water Technologies. This Document and its information are not to be copied, reproduced or delivered to others in whole or part without the expressed written consent and is loaned subject to return on demand. All rights to design and invention are reserved.



50 West Stoever Ave.
Myerstown, PA 17067
1-800-845-3374
www.farmerboyag.com

SERIES BBH-150

DRAWN BY: J.MENDOZA

SCALE: NOT TO SCALE

DATE: 3/8/2021

DWG No. BBH-150